



ALTERNATE ENERGY TECHNOLOGIES, LLC.

AE-SERIES COLLECTORS

**Capturing a clean, renewable energy source
to provide reliable products since 1975.**



AE-Series "Flat Panel" Solar Thermal Collectors, manufactured in The United States of America by Alternate Energy Technologies (AET), are designed to meet the needs of any solar system. Our expert design team will assist in sizing any job to provide hot water, space heating, radiant floor heating or industrial process heat. AET is dedicated to building our AE-Series Collectors from the finest materials and with the highest standards of craftsmanship.

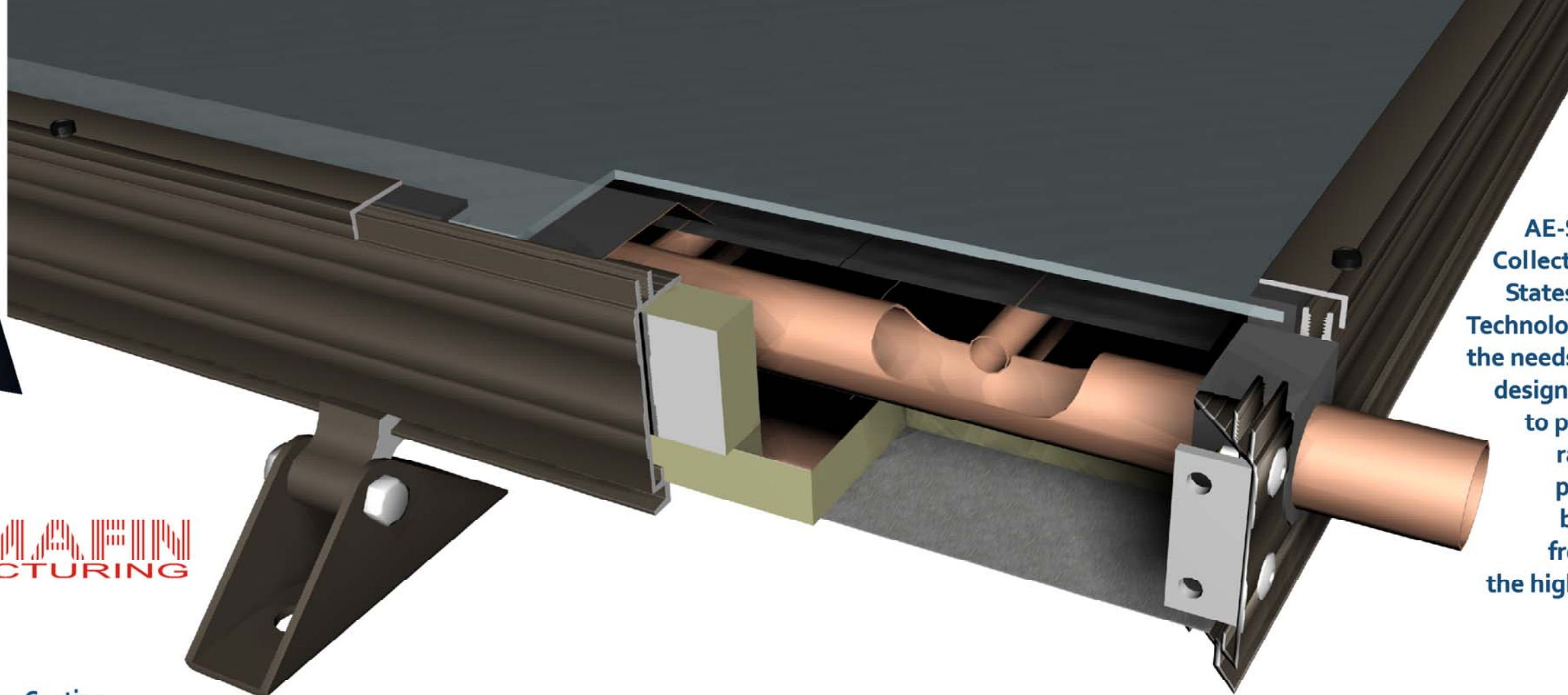

Crystal Clear™ Selective Coating

The Crystal Clear™ Solar-Selective coating is technically a Quartz Encapsulated Bimetallic Alloy. Thousands of nanocrystalline growth projections dramatically increase the surface area of the absorber plate for maximum solar radiation absorption and performance. Crystal Clear™ has been tested for over 14,500 hours at 617°F continuously with minimal visible or physical degradation of its thermal characteristics. Furthermore, Crystal Clear™ by itself enhances the thermal performance of the absorbers by an additional 3%. The finished coating hosts an Absorptivity of > 0.96 & Emissivity of < 0.08

THERMAFIN™ Absorbers

AET introduced THERMAFIN™ absorbers into the AE-Series collectors in 1996. Through extensive research and development, we have employed the best heat transfer method in the world today. THERMAFIN's high-frequency, forge weld process molecularly bonds the fin to the tube providing long-lasting performance and durability while allowing the highest heat conduction. The high-frequency welded joints will not weaken, expand, or pull apart and are backed by a written 30 year guarantee.

Baked Polyester C-Channel Construction

Our AE-Series Collector frames are fabricated in our state-of-the-art manufacturing plant located in Jacksonville, Florida. Crafted using extruded baked polyester (MB-40) electrostatic bronze painted aluminum and securely fastened with aircraft grade pin grip rivets, AE-Series Collectors are built to withstand the most demanding environments.

All AE-Series Collectors Feature:

- Wind load tested to 195 MPH
- Crystal Clear™ selective coatings
- Extruded aluminum frame and battens
- Thermax™ polyisocyanurate foam insulation
- Aircraft aluminum pin grip rivets
- 30+ year design life
- 10 year warranty
- Proudly made in the U.S.A.
- THERMAFIN™ absorber plates
- Quick-lock mounting hardware

COLLECTOR	AE-21	AE-24	AE-26	AE-28	AE-32	AE-40
Length (in)	85.187	97.187	77.187	85.187	97.187	121.187
Width (in)	35.187	35.187	47.187	47.187	47.187	47.187
Height (in)	3.137	3.137	3.137	3.137	3.137	3.137
Gross Area (ft ²)	20.8	23.7	25.3	27.9	31.8	39.7
Transparent Area (ft ²)	19.2	21.9	23.6	26.1	29.9	37.4
Dry Weight (lbs)	74	84	90	99	113	153



Why choose AET and AE-Series Solar Collectors?

- AET and its predecessors are based in the United States and have been manufacturing solar thermal collectors since 1975.
- AET has managers, engineers and installation experts with over 100 years of combined experience in the solar industry.
- All AE-Series collectors feature an attractive low profile skylight design.
- AET's new energy efficient Thermatool solid-state weld head has reduced the carbon footprint of manufacturing solar collectors by 25%.
- AET is proud to provide collectors that are designed for 30+ years of dependable service and carry a full 10 year warranty.
- The AE-Series collector's quick-lock mounting hardware is integrated into the frame wall for easy collector installation and to add to its already attractive design.
- AET collectors are built with quality components to ensure durability and performance.
- Our Crystal Clear™ selective coating is non-toxic and a more efficient electroplating than other coating methods used in the solar industry.

Made in the USA



AE Series Solar Collectors have been constructed to meet the major applicable national and international codes, including the following:

Miami Testing Laboratory
Wind Load Test (ASTM E 330)
Certification No. 94-1028.01

Florida Solar Energy Center
Test Methods and Minimum Standards for Solar
Collectors (ASHRAE Std 93-1986)

Solar Rating and Certification Corporation SRCC
Standard 100-Tested Methods and Minimum
Standards for Certifying. Solar Collectors
(ASHRAE Std 93-1986)

International Association of Plumbing and Mechanical
Officials (IAPMO) • Uniform Solar Energy Code (USEC)
File No. S-5038

Bodycote Materials Testing Canada Inc.
Report No. 02-08-0513

TUV Bayern Sachen e.V. (DIN 4757)
Report No. 28600399

Bundesforschungs - und Prufzentrum Arsenal
ONORM M 7714- Order No. M 4 015



AE-Series Collectors

with exclusive - selective "Crystal Clear" inside

Glazing:
Low-Iron tempered glass, exclusively using our "High-T" tempered glass, with a total solar energy transmission of 90%.

Collector Frame and Battens:
Type 6063-T6 extruded aluminum frame and battens with electrostatic bronze plate finish that facilitates long life and strength.

Insulation:
Polyisocyanurate foam board insulation. Foil-faced, glass fiber-reinforced, rigid board Thermax sheathing (1-1/4" in the bed / 3/4" in the sidewalls).

Mounting Hardware:
The variable "Quick Lock" mounting hardware reduces mounting time and makes it simple for anyone to install. The Quick Lock System allows the highest flexibility in mounting and is tested to wind load conditions of 195 mph. Mounting possibilities include: Pitched roof, Flat roof, Ground, Balcony, and Facade mounting.

Design Life: 30 Years
Warranty: 10 Years
Working Pressure: 165 PSI
Flow Rate: 0.5 to 1.8 GPM (recommended)

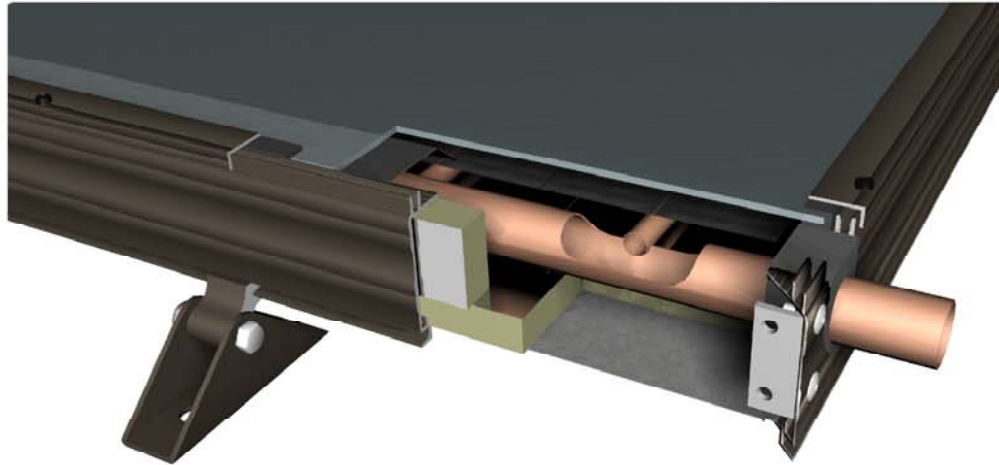

Absorber Plate:
Manufactured by Thermafin™ Mfg., a 100% copper absorber plate, the fin and the riser tube are molecularly bonded by high-frequency forge welding.

Absorber Coating:
Exclusively by Thermafin™ Mfg., a Selective "Crystal Clear" Coating.
 $\alpha = 0.96$ $\epsilon = 0.08$

Gasket Grommets:
A UV durable EPDM, U-channel gasket with molded corners which prohibits water penetration and assures long life. Extruded Silicone Grommet with 1-1/8" Bore.

Corner Bracket:
Architectural aluminum angles inside with aircraft-grade pin grip rivets to ensure high stability.

Fasteners:
5056 Aluminum rivets secure the backsheet. Batten screws are 18-8 SS, 10-24 x 3/8", hex head screws, and black oxide coated.

Backsheet:
Type 3105-H14, 0.019" stucco embossed aluminum sheet (bronze) pop-riveted to aluminum frame.

SPECIFICATIONS						
Collector	AE-21	AE-24	AE-26	AE-28	AE-32	AE-40
Length (in)	85.187	97.187	77.187	85.187	97.187	121.187
Width (in)	35.187	35.187	47.187	47.187	47.187	47.187
Height (in)	3.137	3.137	3.137	3.137	3.137	3.137
Gross Area (ft ²)	20.8	23.7	25.3	27.9	31.8	39.7
Transparent Area (ft ²)	19.2	21.9	23.6	26.1	29.9	37.4
Dry Weight (lb)	74	84	90	99	113	153

CODE APPROVALS

AE-Series Collectors have been designed and constructed to meet major applicable nationwide codes, including the following:

Solar Rating and Certification Corporation
SRCC Standard 100 - *Test Methods and Minimum Standards for Certifying Solar Collectors (ASHRAE Std 93-1986)*

Florida Solar Energy Center - *Test Methods and Minimum Standards for Solar Collectors (ASHRAE Std 93-1986)*

Miami Testing Laboratory
Wind Load Test (ASTM E 3300)
Certification No. 94-1028.01

International Association of Plumbing Mechanical Official (IAPMO)
Uniform Solar Energy Code (USEC)
File No. S-5038

International Testing

Bodycote Materials Testing Canada Inc.
Report No. 02-08-0513

TÜV Bayern Sachen e.V. (DIN 4757)
Report No. 28600399

Bundesforschungs - und Prüfzentrum Arsenal
ÖNORM M 7714 - Order No. M 4 015

AE-Series Collectors

Mounting Hardware Options

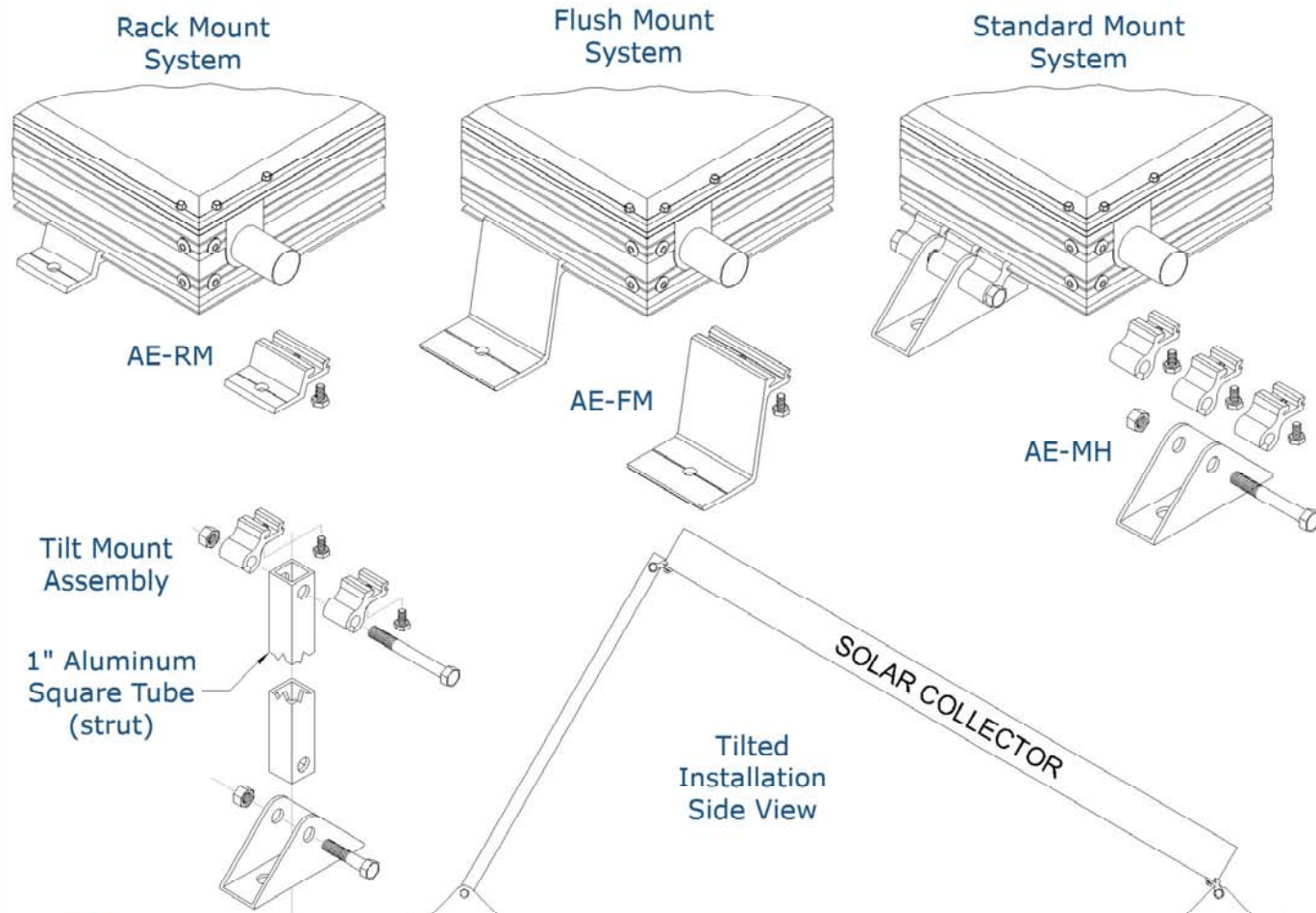

AET's exclusive "Quick Lock" mounting systems allow for virtually any collector orientation and mounting. Collectors can be mounted to any roof, vertical wall, fascia boards, pre-constructed racks or ground mount systems. The framewall and mount have been certified to withstand 180 mph winds. The framewall will accept the mounts anywhere around the collector without drilling or tapping, so the integrity of the framewall is not violated. The rear struts can be cut to any length allowing proper elevation and orientation.